

Solutions for Perfection from Marin Industrietechnik

Heavy Weight Weaving Shuttles VRK-N1

- *10-15 % Higher productivity utilization*
- *Cost reduction due to long life materials*
- *Cost saving due to modular construction*
- *No weaving marks on the fabric*

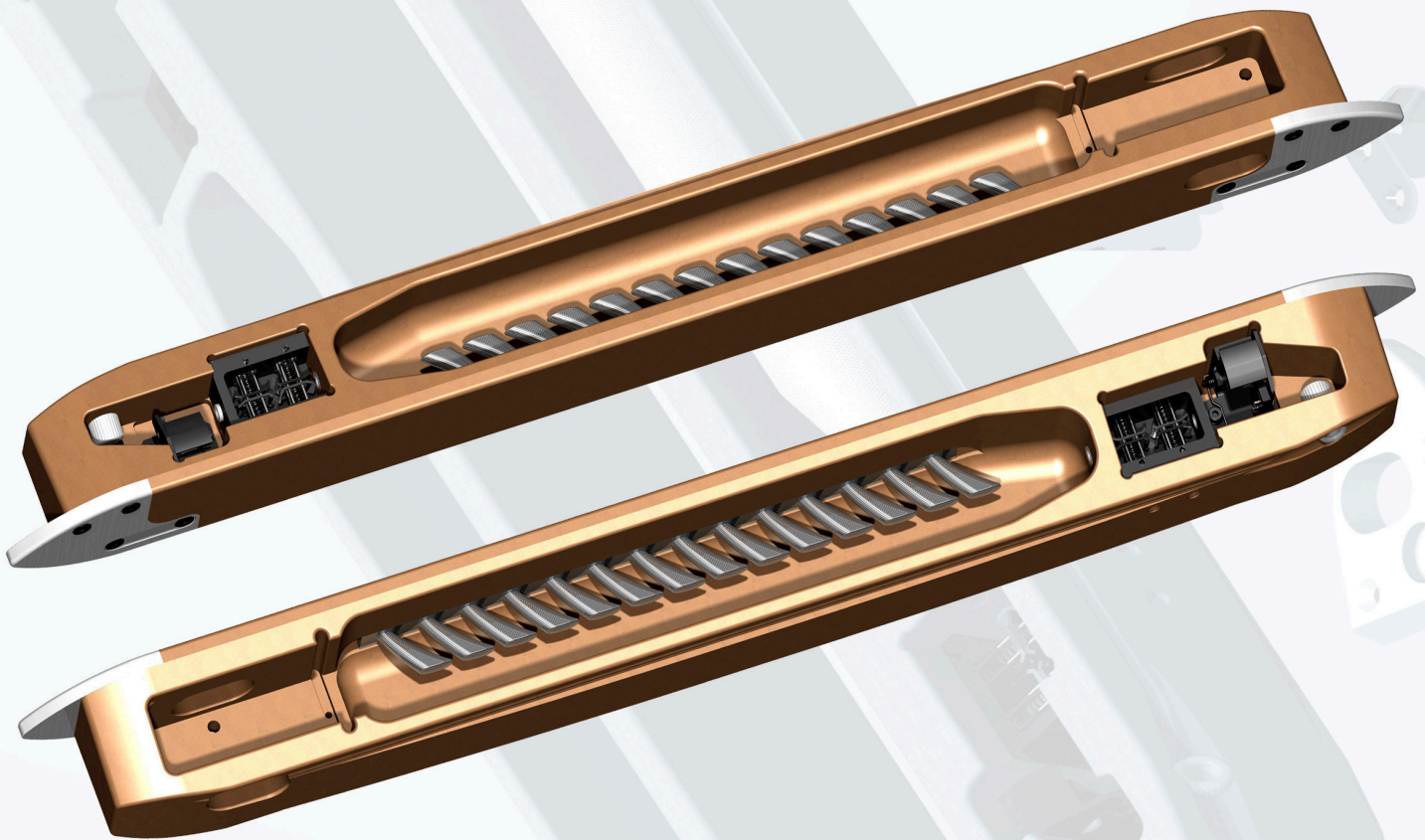

Regional Agent 區域代理:
A&A Consultant 香港A&A諮詢
www.hkaac.net

@: info@hkaac.net ☎: +852-9023 4800
✉: PO Box 143, Tung Chung, HONG KONG (香港)

MARIN
Industrietechnik

Weaving Shuttles Type VRK-N1

High-Tec Shuttle type VRK-N1, with polished sliding skids and full equipment. Application: Felt weaving looms with hydraulic insertion system and automatic pin changer on the right loom side. Changeable brush strips will be integrated customer specific.

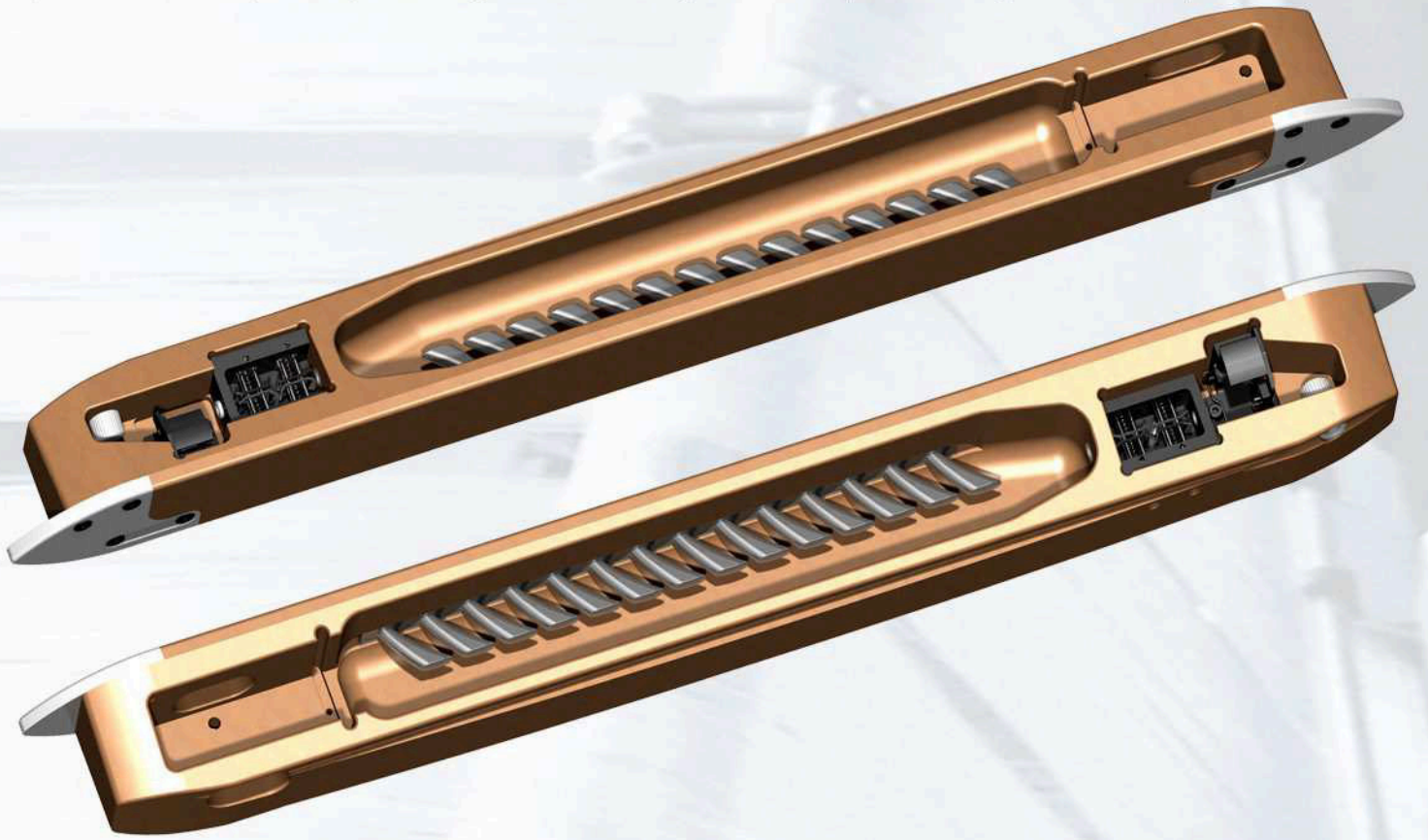

Full equipment:

2 Ceramic eyelets, 1 Shuttle nose type VRL, 1 Shuttle nose type VRR, 2 Sensor plates type V, 1 Yarn cutter type A, 1 Filling brake type BR, 1 Brush strip 325 mm or 350 mm and all screwing connections.

Shuttle dimensions:

750/700x80x67/50 mm.

Pirn positioning parts:

The pirn positioning unit and the pirn holding web have to be provided by the customer.

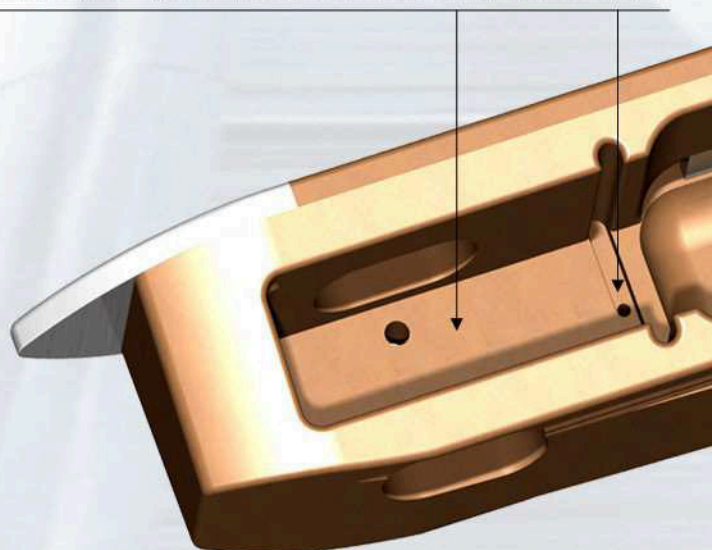

Weaving Shuttles Type VRG-N1

High-Tec Shuttle type VRG-N1 on the highest precision level with basic equipment

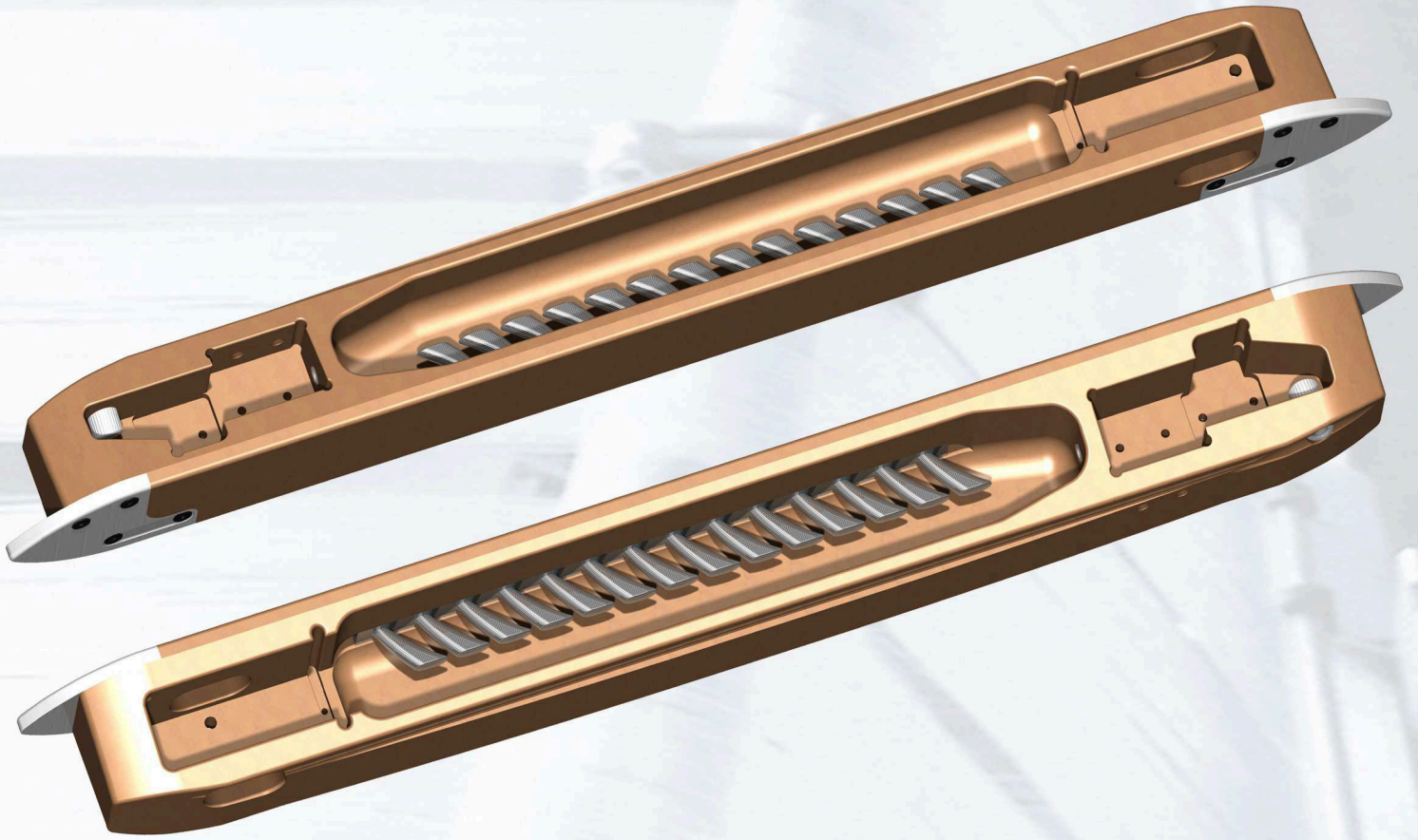

Basic equipment:

2 Ceramic eyelets, 1 Shuttle nose type VRL, 1 Shuttle nose type VRR, 2 Sensor plates type V, 2 locking nuts, 1 Brush strip 325 mm or 350 mm.

Shuttle dimensions:

750/700 x 80 x 67/50 mm

MARIN
Industrietechnik

Lechstrasse 2
73529 Schwabisch Gmuend
Germany

fon: + 49 (0) 7171 98 90 52
fax: + 49 (0) 7171 98 90 53

email: info@marin-technik.de
home: www.marin-technik.de