

Solutions for Perfection from Marin Industrietechnik

## Heavy Weight Weaving Shuttles ARK2-N1

- *10-15 % Higher productivity utilization*
- *Cost reduction due to long life materials*
- *Cost saving due to modular construction*
- *No weaving marks on the fabric*

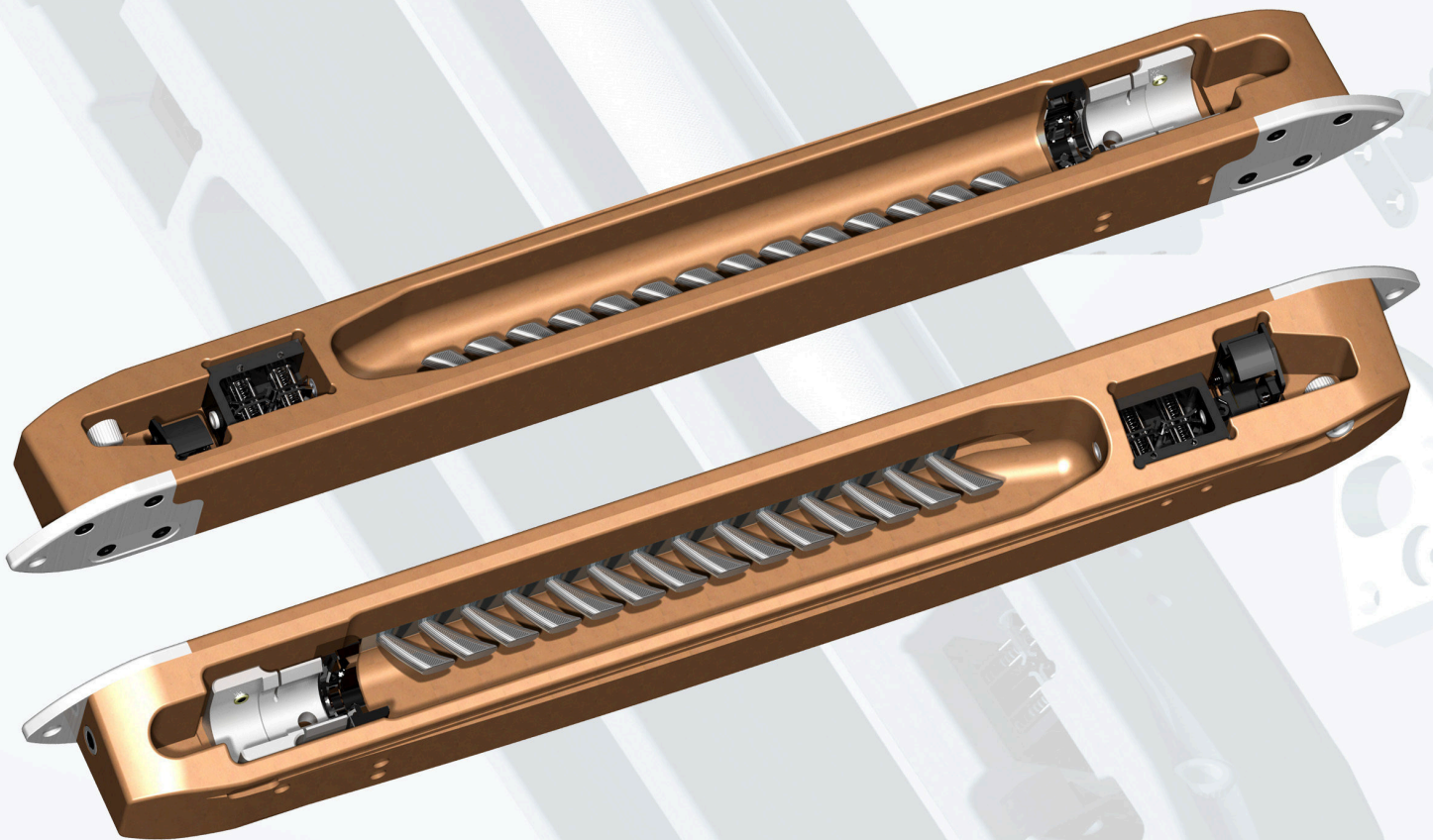

Regional Agent 區域代理:  
A&A Consultant 香港A&A諮詢  
www.hkaac.net

@: info@hkaac.net ☎: +852-9023 4800  
✉: PO Box 143, Tung Chung, HONG KONG (香港)

**MARIN**  
Industrietechnik

## Weaving Shuttles Type ARK2-N1

High-Tec Shuttle type ARK2-N1, with polished sliding skids and full equipment. Application: Felt weaving looms with hydraulic insertion system and automatic pirn changer on the right loom side. For pirns with cylindrical end-shape without steel rings. Changeable brush strips will be integrated customer specific.

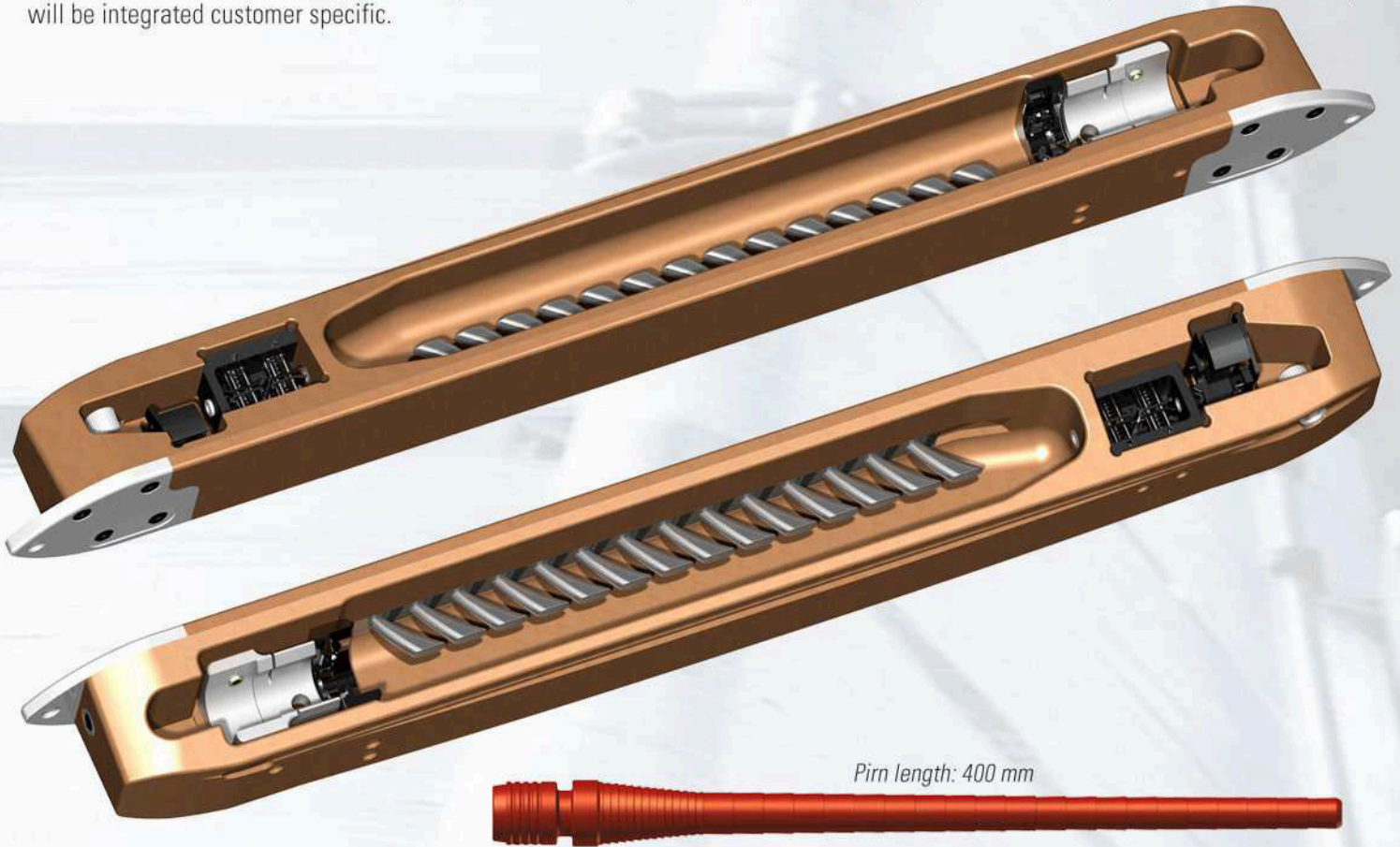

### Full equipment:

2 Ceramic eyelets, 1 Shuttle nose type ARL, 1 Shuttle nose type ARR, 2 Sensor plates type A, 1 Clamping spring type TEXV, 1 Pirn holder type TEX, 1 Yarn cutter type A, 1 Filling brake type BR, 1 Brush strip 325 mm, 1 Drill bush and all screwing connections.

### Shuttle dimensions:

750/700x80x67/50 mm.

Clamping spring type TEXV

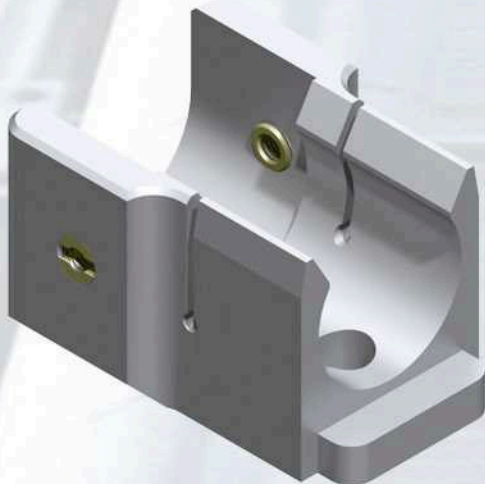

Pirn holder type TEX

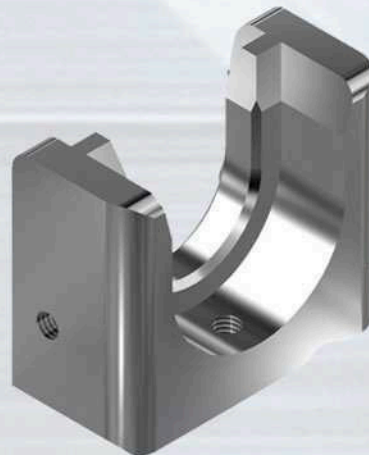

## Weaving Shuttles Type ARG2-N1

High-Tec Shuttle type ARG2-N1 on the highest precision level with basic equipment

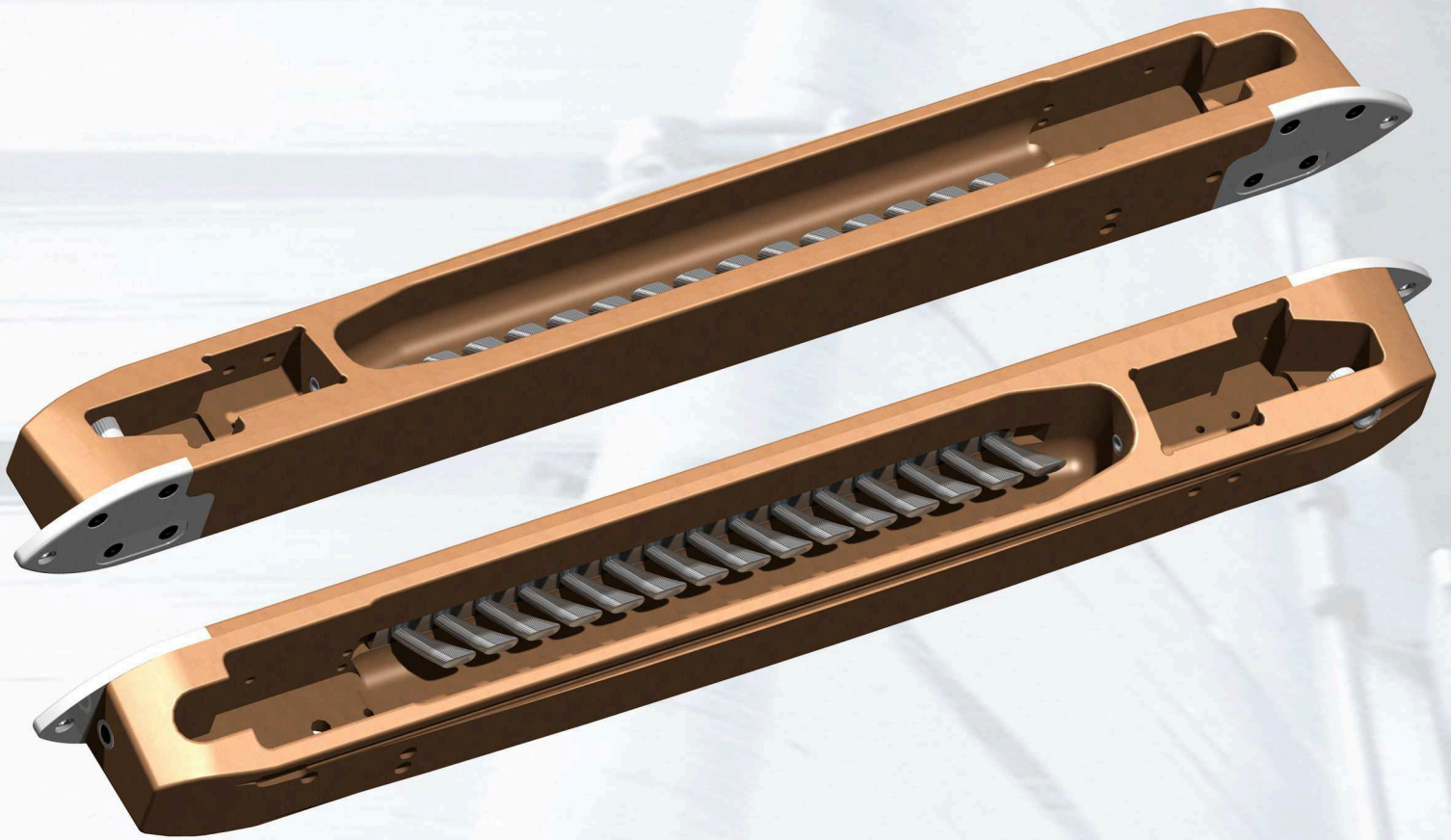

### Basic equipment:

2 Ceramic eyelets, 1 Shuttle nose type ARL, 1 Shuttle nose type ARR, 2 Sensor plates type A, 2 locking nuts, 1 Brush strip 325 mm and 1 Drill bush at the left picking surface for pirn changer positioning.

### Shuttle dimensions:

750/700 x 80 x 67/50 mm

**MARIN**  
Industrietechnik

Lechstrasse 2  
73529 Schwabisch Gmuend  
Germany

fon: + 49 (0) 7171 98 90 52  
fax: + 49 (0) 7171 98 90 53

email: [info@marin-technik.de](mailto:info@marin-technik.de)  
home: [www.marin-technik.de](http://www.marin-technik.de)